



AGRICULTURE
SOLUTIONS



A Growing Portfolio that Brings the Power of Precision to Farming Operations around the World

Topcon serves agribusinesses, professional farmers and agricultural contractors with leading edge, innovative technology that is easy-to-learn and easy-to-use. Our solutions make a difference. With over 40 years invested in providing advanced technology products designed to improve farm efficiency worldwide, Topcon Agriculture solutions increase productivity and profitability throughout the farming cycle.

Expansion of the Topcon family of brands has enabled us to reach across all phases of precision farming and into additional agriculture sectors with weight sensors and specialized monitor/control systems for solutions from planting through harvest to include animal feeding solutions.

WACHENDORFFElektronik — TOPCON POSITIONING GROUP —

Wachendorff technology creates the ideal interface between man and machine. Wachendorff joining the Topcon family created the world's largest developer and manufacturer of in cab consoles, serving the agricultural and construction markets.

NORAC — TOPCON POSITIONING GROUP —

NORAC Systems International is a pioneer and the world's leading developer of ultrasonic sensing for boom height control technology on agricultural equipment. Its automated boom height control technology has helped boost Topcon to a leadership position in the precision application control sector.

DIGI★STAR — TOPCON POSITIONING GROUP —

Digi-Star is an international provider of measuring solutions for optimizing agricultural performance. Digi-Star weighing and tracking products are an ideal interface with Topcon Agriculture solutions for animal weighing and feeding, planting, spraying, spreading and harvest operations.

RDS TECHNOLOGY — TOPCON POSITIONING GROUP —

RDS Technology specializes in instrumentation for the agricultural and mobile machine markets. RDS has a 40 year history of innovative solutions from optical based yield monitoring to solutions for balers and wrappers. RDS has been a world leader in mobile weighing and control solutions.

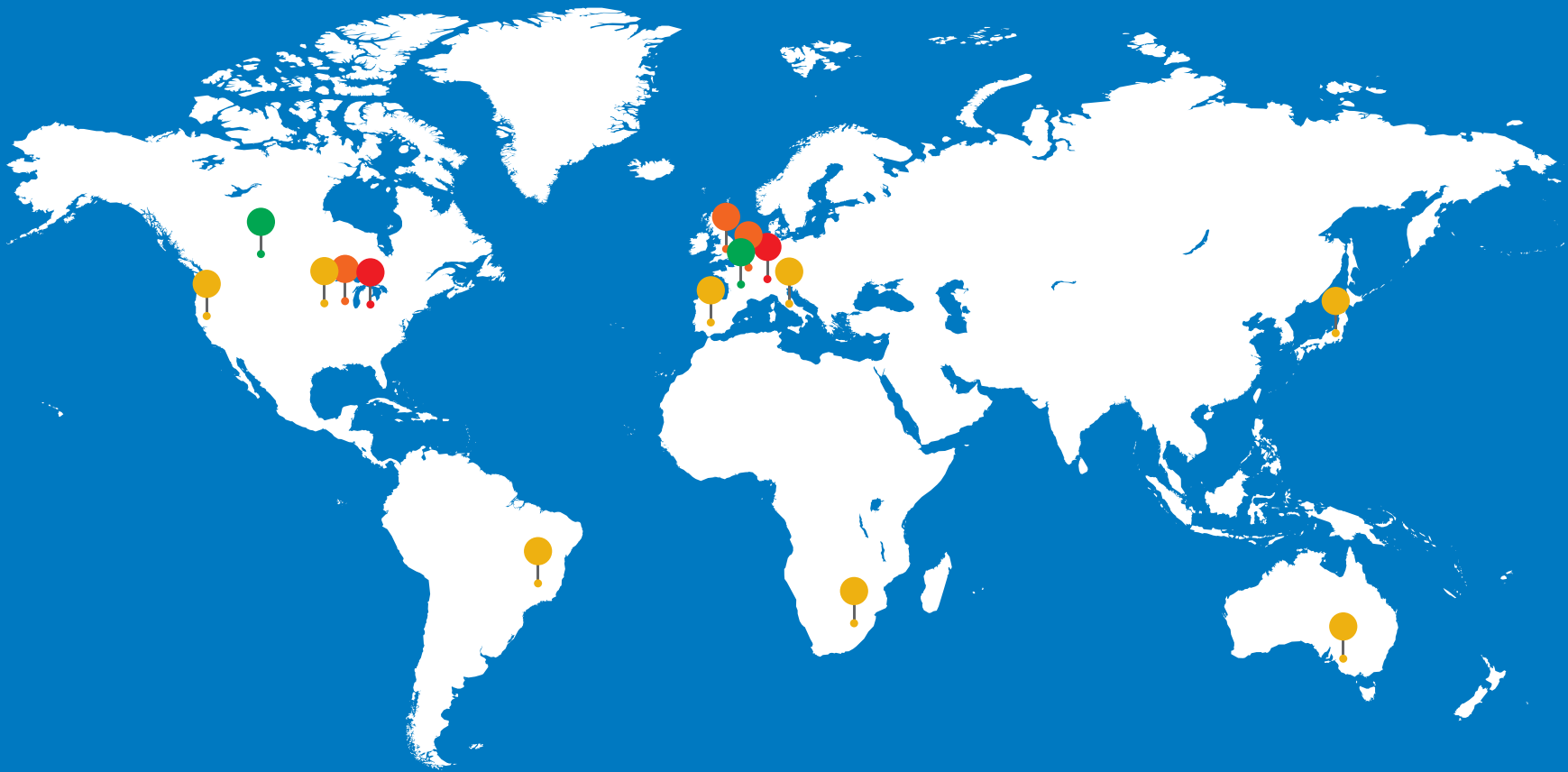

DIGI★STAR
— TOPCON POSITIONING GROUP —





With You All the Way

No matter what size farm or agribusiness, what role you have, or what season it is, Topcon has the solutions and services to help you get the job done right.

Topcon brings improved efficiency and productivity to every phase of your farming operation.

With a proven track record of dependable and reliable products that stand up to the challenge of farm work, Topcon combines precision positioning technology and advanced machine control to help you increase productivity, reduce inputs and maximize farm revenue. In an effort to keep your farm operating throughout the growing season, dealers have access to 24/7 support from the factory.

Inside you'll find the tools you need to get your work done the right way, the first time.



Table of Contents

A Global Positioning Company	2-3
With You All The Way	4-5
Consoles	6-11
Accuracy and Autosteering	12-19
Planting and Seeding Solutions	20-25
Growing Solutions	26-35
Harvest Solutions	36-39
Animal Feeding Solutions	40-43
Preparation and Planning Solutions	44-51



Topcon X Family Consoles

More choices in precision means better decisions

Full-color touchscreen displays, with Horizon software, take precision machine control to new levels of performance and ease-of-use.

The Topcon X Family of multi-touch guidance consoles brings innovative, industry-leading performance and ease-of-use to virtually any size farming operation that is seeking to use precision to improve operational efficiency and reduce input costs.



Horizon Software

Horizon software is the user's portal to easily interface with the X Family of Topcon touchscreen consoles. It has been developed to allow users to customize their views, so the software becomes intuitive to learn and operate.



Virtual Display Controller (VDC)

The VDC is a programmable user interface (UI) that makes repetitive tasks as simple as a button push. The VDC can mount on the armrest near the operator for easy access. It is designed to avoid the need to reach for the screen in rugged field conditions.

AgCam Interface for X30 Consoles

Get high quality on-screen video in any light condition, day or night, displaying up to two selectable camera views on the X30 touchscreen console. Solid-state, rugged and waterproof, with strong magnetic mounts, AgCams are easily positioned or moved among vehicles or implements.



X14 Console (4.3" Touchscreen)



An entry-level console with a simple, easy-to-use full-color 3D touchscreen offering moving map guidance or autosteering, as well as a virtual on-screen lightbar.

- Full range of manual and autosteering patterns
- Simple, intuitive, icon-based, user-definable interface
- Easy setup on leading market vehicles
- Bright, sunlight-readable display
- Upgradeable to support auto-section control
- Easy-to-learn, easy-to-use, easy to upgrade as needs grow

X25 Console (8.4" Touchscreen)



Full-featured, 3D color touchscreen offering precision machine control and high-accuracy autosteering for the more price conscious farmer and smaller cab environments.

- Full range of manual and autosteering patterns
- Multi-touch display with 2 mini-views and 1 main view
- Full mapping and data management capability
- Full ISO UT and ISO TC embedded
- Basic and advanced feature packages for any size operation
- Exportable boundary, coverage, logging and as-applied maps
- Easy-to-learn, easy-to-use, easy to upgrade as needs grow

X30 Console (12.1" Touchscreen)



The X30 has a well-earned reputation as the easiest-to-use console on the market, including an all-in-one design that reduces cab clutter.

- All-in-one system
- Multi-touch display with up to 3 mini-views and 1 main view
- Variable rate control (VRC) for up to 8 products
- 30-section auto section control (ASC) of sprayer, spreader and planter
- Up to 32-section ASC ISO Task Controller (TC) interface
- Easy-to-learn and easy-to-use

Topcon Console Comparisons

	X14	X25	X30
Features			
Diagonal Screen Size	4.3" (10.9 cm)	8.4" (21.3 cm)	12.1" (31 cm)
3D Graphics	X	X	X
Touchscreen	X	X	X
Gestures/Slide Functionality	X	X	X
On-Screen Navigation Menus	X	X	X
Mini-views (widgets)		2	3
User Configurable Dashboard	X	X	X
User Configurable Home Screens		X	X
Sunlight Readable	X	X	X
Lightbar Compatible	On-Screen	On-Screen	Integrated
Modular (independent of GPS)	X	X	X
Steering Patterns			
AB Line	X	X	X
Identical Curve	X	X	X
Guide from Previous Coverage (GuideLock)	X	X	X
Pivot	X	X	X
Controlled Traffic		X*	X*
Working Modes			
ASC-10 Based Section Control	10	30*	30
ISO-Based Section Control		32*	32
Spreader Section Control	X	X	X
Sprayer	X	X	X
Compatible w/Boom Leveling via ISO		ISO-UT / NORAC	ISO-UT / NORAC
Spinner/Spreader		X	X
Straight Rate Product Control	1	4*	8
Variable Rate Product Control		4*	8
Topcon Air Seeder Control			X
Air Seeder Downforce Control			X
Row Crop Planter Interface		ISO-UT / ISO TC*	ISO-UT / ISO-TC
Water Conservation and Landforming			X

	X14	X25	X30
Mapping and Documentation			
Coverage	X	X	X
Implement Depth for Spreaders/Seeders		X	X
PDF Job Report	X	X	X
As-Applied Data	X	X	X
ISO TaskData Compatible		X	X
HD Prescription Mapping Support		X	X
Import/Export .shp file	X	X	X
Import/Export ISOXML		X	X
Compatible with SGIS	X	X	X
Special Features			
Return-to-Point	X	X	X
Geo-locate Stored Fields	X	X	X
Job Setup Wizard	X	X	X
Import Implement Library	X	X	X
Remote Diagnostics			X
USB Camera Compatibility		2**	2
Xlinks 3rd Party ECU Control		X*	X*
Upgrade Options			
ASC-10 Rate and Section Control		X	X
Apollo Application Controller ECU		X**	X
ISO 11783 compliant ECU		X	X
CropSpec Crop Canopy Sensors		X	X
Receiver Compatibility			
SGR-1	X	X	X
AGI-3/AGI-4	X	X	X
Accepts NMEA-0183	X	X	X
Simulated Radar Output		X	X
Receiver GNSS and SBAS Filtering	TruPass	TruPass	TruPass
Steering Control (External)			
AGI-3	X	X	X
AGI-4	X	X	X
AES-25 Compatible	X	X	X

* Requires unlock codes which are additional cost options. ** Available in future release

WACHENDORFFElektronik
— TOPCON POSITIONING GROUP —

World leader for in-cab consoles and machine Interface

Creating the ideal interface between man and machine - innovative, high performance consoles from Wachendorff populate the global agriculture, construction and utility markets used by many of the world's leading Original Equipment Manufacturers (OEM) for industrial machines.

Wachendorff is a world leader in engineering and manufacturing of consoles that hold up to the rigors of outdoor applications. Equipment manufacturers around the world use their products, manufactured in Germany to exacting standards and quality. Wachendorff products are high quality, dependable, durable, and reliable.

The Wachendorff combination of innovative engineering and manufacturing excellence delivers peak-performing products at all times. Their high visibility interactive displays ensure that productivity is increased, costs are reduced and value is added across all types of agricultural and industrial applications.

The Wachendorff Projector Tool

This computer program enables Original Equipment Manufacturers to develop a look and feel that is best for their customers and is unique to them, and their equipment. Graphical screens and visualizations can be created with minimal training. The Wachendorff graphical library has resources to meet a host of applications for a variety of specialty equipment and uses.



Agricultural Consoles that raise the bar for any agricultural solution

OPUS A3s

Big Performance, Small Package



The OPUS A3s allows implementation of a variety of different user interfaces with ease. This light weight device offers highly practical, everyday use and easy interface with your precision system.

- 4.3" display features operation verification
- Screen can be supplied as analog resistive touchscreen in either landscape or portrait orientation
- Encoder, 8 softkeys and 3 hard keys with exceptional tactile touch
- Multi-color LED supplemented by 3 additional LEDs
- Front facing USB 2.0 for high-speed data exchange
- CANbus ports for fast operation
- Powerful 32-bit, 532 MHz processor for outstanding performance

OPUS A6s

For Perfectionists Seeking Convenience



The high degree of automation in today's machines creates large volumes of output daily. For these data-hungry precision applications, OPUS A6s is the solution.

- Bright, 7" display with up to 3 video inputs
- High-speed USB 2.0 interface
- Problem free functionality ensured with Embedded Linux OS
- Available in standalone or dashboard solution
- 12 softkeys and 3 hard keys, plus 4 digital or analog inputs
- Multi-color LED and standard LED for immediate fault detection/indication
- High performance, 32-bit, 532 MHz processor with 512MB or 1GB memory











What do you need to do?

Topcon offers the accuracy solutions to do it

Some crops require sub-inch accurate corrections to be produced with the most profitability, while others do not need such precision. Topcon offers correction accuracies from entry-level, sub-meter to high-accuracy, sub-inch.

All of the Topcon precision agriculture solutions start with GNSS (Global Navigation Satellite System) accuracy. Topcon receivers are all standard with GNSS dual-constellation (GPS + GLONASS) satellite reception. Topcon GNSS also offers TruPass™ mode for improved autonomous pass-to-pass accuracies.

Whether you are after entry-level guidance or need sub-inch, repeatable RTK (Real-Time Kinematics) accuracy, Topcon modular-designed products let your GNSS technology grow as your operation expands.

Accuracy Type	Pass-To-Pass*	Typical Uses	GNSS	Displays
RTK	1-2" 2-5 cm Repeatable	Strip Tillage Landforming/Leveling Topographic Mapping Listing/Planting Bedding/Ridging Cultivating	AGI-4 	X30 X25 X14 
CORS/NTRIP	1-12" 2-30 cm	Listing Planting/Seeding Cultivating Bedding/Ridging	AGI-4 	X30 X25 X14 
OmniSTAR VBS XP/HP/G2 Dual Frequency (L1/L2)	3-4" 8-10 cm	Tillage/Discing Mapping Spraying/Spreading Harvest Field Preparation	AGI-4 	X30 X25 X14 
DGPS WAAS EGNOS MSAS VBS L1 Only	4-12" 10-30 cm	Tillage/Discing Mapping Spraying/Spreading Harvest Field Preparation	AGI-4 SGR-1 	X30 X25 X14 

SGR-1 Receiver

Featuring Topcon TruPass™ Advanced Positioning Technology

This compact, rugged receiver provides simultaneous processing of GPS and GLONASS signals with 32-channel high speed, universal tracking. The SGR-1 features Topcon TruPass advanced positioning technology for higher, more stable pass-to-pass accuracies in dynamic ag applications. The SGR-1 outputs ground speed as simulated radar for fewer on board components during operations such as seeding and spraying.



HiPer V Base Station

Compact GNSS Positioning and RTK Correction

The Topcon HiPer V GNSS base station is compatible with Topcon receivers from field crop autosteering and machine control to water conservation and landforming. The HiPer V is a one-piece, cable-free unit that is rugged and compact featuring 226-channel Vanguard Technology™ along with patented Fence Antenna technology for advanced performance. GNSS (GPS + GLONASS) tracking provides the ultimate in accuracy while offering field proven design.



GR-5 Base Station

Premium Portable Base Station

The latest GR-5 features the Topcon Vanguard GNSS chipset with 226 universal channel Tracking Technology. The GR-5 also includes Topcon's patented Fence Antenna Technology™ design which offers a compact and lightweight antenna that covers the entire GNSS frequency band for unmatched performance. With Vanguard chipset, Fence Antenna, and Topcon's advanced acquisition algorithms, the GR-5 receiver delivers the most robust GNSS tracking performance available.



MR-1 Base Station

Permanent Base Station

The MR-1 receiver delivers proven Topcon technology in a compact and easy to integrate package. It is ideally suited for permanent setups using an external antenna, external radio and separate power supply. It incorporates 72 Universal Tracking Channels and is capable of tracking all signals from GPS, GLONASS and SBAS satellite systems. The MR-1 is built for harsh environments, offering IP67 dust and water resistance as well as a superior level of vibration and shock tolerance.



SRL-35 Radio

High-Power Repeater

Pushing out 35 watts, the SRL-35 provides reliable signal strength in the most challenging of environments. Built to IP67 standards, the light and portable radio features a weather-protected LCD display, integrated operator keyboard, and reinforced connectors. It can be used with an RTK Base or as a stand alone RTK repeater.



TopNET *live*

GNSS Reference Station Network

TopNET live is a subscription based, real-time GNSS reference network delivering high quality correction data for agricultural applications throughout the globe.

TopNET live networks deliver consistent, high precision solutions to rovers used in a variety of agricultural applications such as planting, fertilizing, chemical application and land leveling. Using a modeled solution (NET-RTK), rovers within the network coverage area benefit from fast, reliable initializations and maintain high quality positioning solutions at all times.

www.topnetlive.com



AGI-4 Receiver/Steering Controller

The first truly modular ISO-compliant steering system

The AGI-4 comes standard with WAAS and EGNOS, but is easily upgradeable to 2 cm accuracy with RTK radio options. Like all Topcon receivers, the AGI-4 offers GNSS multi-constellation satellite reception standard for unmatched accuracy in dynamic applications and all terrain conditions.

The all-in-one, modular design incorporates the antenna, receiver and steering controller in a single component, offering unmatched upgradeability. The AGI-4's ISO11783 compliant steering system features state-of-the-art inertial sensors and full terrain compensation for superior line acquisition and holding capabilities.

NTRIP capability allows tapping into existing reference networks via cellular connection (dependent of local availability) and uses existing data plans and infrastructure to minimize costs. In addition, the AGI-4's ISO11783 compatibility with other Universal Terminals (UT) provides drop-in and drive convenience.



Controlled Traffic Farming

Topcon X30 Optimal Lines produces controlled traffic farming with unmatched versatility

Originally created to reduce plant damage in sugar cane applications, Optimal Lines provides many additional benefits in farming situations where accurate repeatability coupled with flexibility in GPS lines is needed to accommodate varied field conditions and equipment setups over an extended time period.

Controlled Traffic Farming (CTF) reduces soil compaction damage caused by heavy or repeated passes over the land. The negative consequences are well documented and include increased fuel usage, poor seedbeds, reduced yields and poor soil function in terms of water infiltration, drainage and greenhouse gas mitigation.

A CTF system confines machinery to the least possible areas of permanent traffic lanes. Without this control, machines can run randomly over the land, compacting as much as 75% of the area within one season and the entire area by the second season. Soils can take years to recover. A proper CTF system can improve yields by reducing tracking to just 15% and it always occurs in the same place.



X30 coupled with Topcon RTK, Optimal Lines offers repeatable performance over years.



AES-25 Electric Steering

Optional AES-25 provides hydraulic performance with electric convenience

For non-steer-ready vehicles, the AES-25 Electric Steering System fits the bill. Fast, flexible and extremely accurate, it is a superb alternative to common hydraulic steering. With a quiet, high-torque, direct-drive electric motor, the AES-25 provides silent operation while producing the most accurate electric steering in the world.

AES-25 brings best-in-class performance to a wide range of ag applications, including sprayers, windrowers and combines, in addition to being the perfect solution to non-steer-ready tractors.

- Fast, accurate steering response
- Easily transferable across vehicles
- Compatible with X30, X25 and X14
- Up to 2 cm performance accuracy with RTK
- Improved accuracy with wheel angle sensor
- Full terrain compensation
- Convenient, easy installation
- Reverse operation



ACU-1

Direct Interface Steering



The ACU-1 is compatible with a wide range of “steer-ready” vehicles using high-speed CANbus communications.



Seeding Solutions

The future of seeding technology is here today

Apollo Application Controllers

Apollo brings world leading seeder control experience in a next generation package for an integrated solution to small grain seeding systems. Apollo ECU's are easy-to-install, easy-to-use, stackable, weatherproof, ISO compatible, and most importantly, offer virtually unlimited capabilities.

Apollo application control ECU's are configurable to support a wide range of air seeders – virtually every brand currently on the market. You get advanced air seeder functionality in an easy-to-use, dependable and reliable package.

From simple single product seeding to multi-product seed, chemical and fertilizer applications, Apollo ECU's running with Topcon GNSS autosteering bring it all together in a synergistic system offering unmatched efficiency and productivity.



CM-40 Control Module (top) is ISO11783 compliant with multiple encoder, digital and analog inputs. It can control up to 4 independent application control channels and provides up to 10 outputs.

EM-24 Expansion Module (bottom) is designed for additional section control and blockage monitoring controlled by CM-40 with up to 40 inputs and 24 outputs.



[Apollo works hand-in-hand with Topcon X30 console and Horizon software](#)

The Topcon X30 console, exclusive with Horizon software, gives Apollo an advanced, one touch interface in an easy-to-use, high visibility format for unmatched seeding control. Combining rate control, path planning, high accuracy GNSS steering and full agronomic data control, it is already setting new standards in the seeder market.

Apollo offers up to eight product control channels and can run Variable Rate Control on all eight simultaneously including liquid, dry and NH_3 . It offers Section Control for dry, liquid or NH_3 on each boom independently, plus optional blockage monitoring of 100+ lines.



[KP-12 CAN based keypad for optimum convenience](#)

For in-cab use during operation or out on the air cart for calibration, the KP-12 simplifies setup and operation of Apollo Application Control. The in-cab keypad has user assignable buttons to control multiple functions: implement lift/lower, increase rate/down force pressure, auto/manual for liquid tanks and more. The on-frame keypad can be used for functions outside of calibration such as priming tanks (proportional drive granular only) and lifting or lowering the drill.

[Topcon XLinks for easy interface with existing controller](#)

The XLinks option allows the interface of an existing controller with the Topcon X30 console to provide auto section control (ASC) and variable rate control (VRC). XLinks provides VRC using Topcon industry leading easy-to-use interface with a variety of existing controls, including Topcon's MDECU and legacy offers recording of as-applied data. XLinks allows a controller with basic functionality to maintain usability versus re-wiring the implement and installing a new control module.



Seed Monitoring Solutions



RDS Seed Drill Monitor (MFDC 100)

A user friendly and cost effective method of monitoring a number of seed drill operating functions and controlling tramline sequences.

- Monitors forward speed, part/total area, fan speed, shaft RPM and hopper level.
- Programmable tramline



RDS Shaft Speed Monitor (SSM600)

An easy to use and cost effective method of monitoring up to 4 different shaft speeds simultaneously on any implement where it is important to monitor the RPM of individual shafts.

- Monitors up to 4 shaft speeds (0-9999 RPM)
- Monitor forward speed, part/total area
- Programmable high/low speed warning alarms



Planting Solutions

ISO compatible planter control up to 32 rows

Topcon precision solutions for row crop planters are ISO-based and interface with a number of ISO compatible planters including White, DICKEY-john and Kinze. The Topcon planter interface also supports auto section control and variable rate control via ISO Task Controller (TC).





Automated Seed Weighing Solution



Seed Tracker™

Precision automated management system designed specifically for seed tenders

An easy-to-use, high-accuracy, full-featured weighing and planting management tool for tracking seed weights of up to 10 individual boxes or bulk bins. Save time while your Topcon precision steering and machine control systems are saving on input costs.

- Reduce co-mingling of seed varieties – preset amounts with less clean-out
- Eliminate downtime with convenient “no-fail” Start/Stop function
- Measure seed used between farms and partnerships
- Manage multiple farms with downloadable information
- Easily verify quantity of seed delivered

ST 3400 Indicator

Compatible with all load cell equipped seed tenders, including tenders equipped with variable throttle systems, the ST 3400 features preset weights with pre-programmable auto shut-off for delivering precise quantities of seed – time after time provides an accurate read of weight of seed remaining in bins along with accumulation of weights per field entry. Navigational keypad reviews previous loads or allows editing of field information.



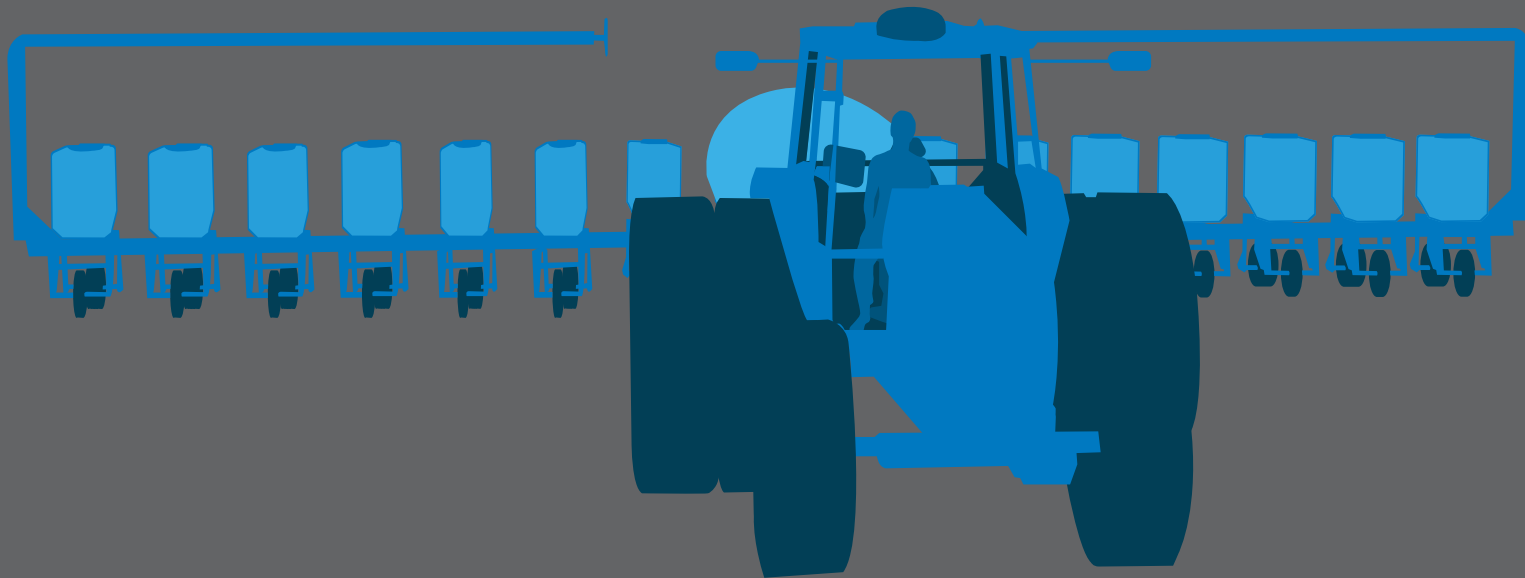
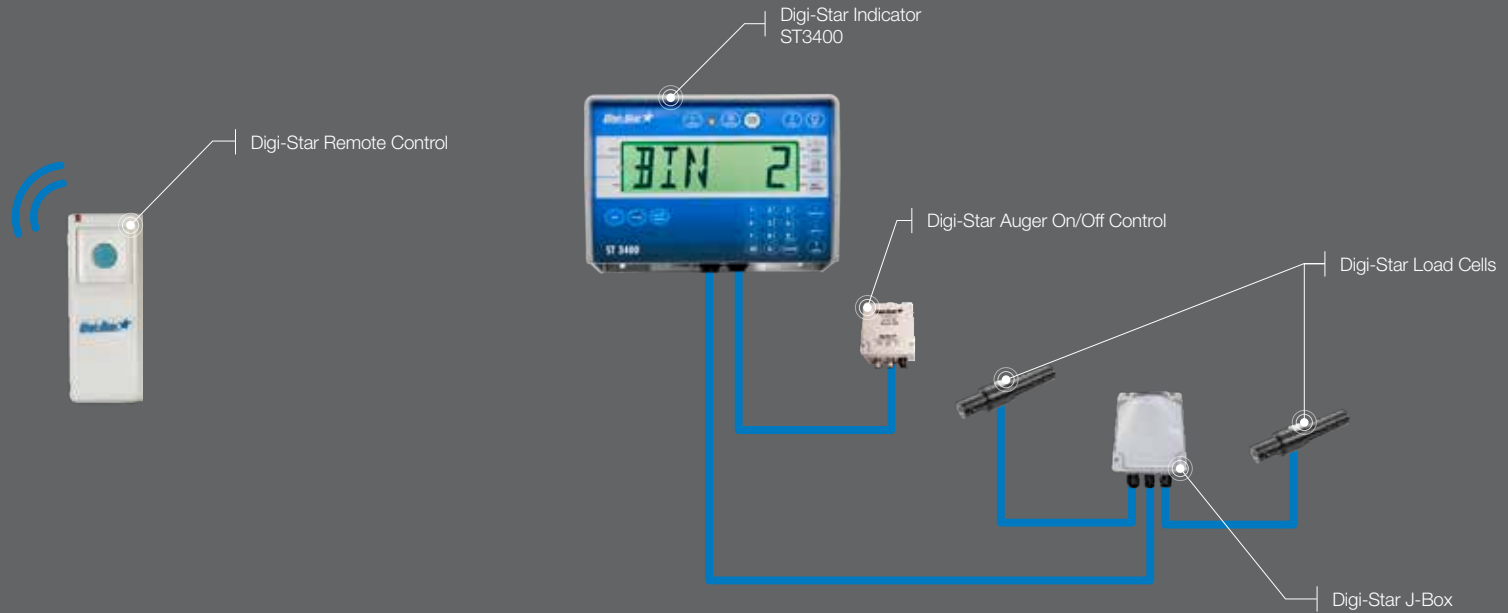

Spraying Solutions



State-of-the-art sprayer control starts with topcon consoles and horizon software

Both the X30 and X25 consoles offer full-featured spray control and data management with exclusive Topcon Horizon software interface. Horizon is intuitive to learn, easy to operate, and allows users to customize views to fit their specific operation.

Entry level section control for the smaller operator

The Topcon ASC-10 auto section controller is the easy, economical way to bring rate and section control to a sprayer. It has the ability to interface with the Topcon X Family of consoles (X14, X25 and X30) and up to 3 ASC-10 units can be connected to provide up to 30-section control. A single ASC-10 provides 10 section control. ASC-10 also offers liquid rate control that provides consistent uniform application rate control as operating speeds varying across a field.

X25



X30



Apollo spray application controllers add industry-leading sprayer Control solutions

Apollo is a state-of-the-art concept in integrated machine control ECU's that brings industry-leading variable rate control (VRC) and auto section control (ASC) to sprayers. The ECU's are easy-to-install, easy-to-use, stackable, weatherproof, ISO compatible, and most importantly, offer virtually unlimited capabilities.

Apollo offers up to eight product control channels and can run variable rate control on all eight simultaneously. It also offers section control on each boom independently. Apollo application control ECU's are configurable to support a wide range of sprayer makes and models.

CM-40 Control Module (top) is ISO11783 compliant with multiple encoder, digital and analog inputs. It can control up to 4 independent application control channels and provides up to 10 outputs.

EM-24 Expansion Module (bottom) is designed for additional section control expanding from the CM-40 with up to 40 inputs and 24 outputs.



ISO Universal Terminal (UT) for multi machine compatibility

ISOBUS allows different implements to connect to Topcon consoles and display implement functionality on the Universal Terminal screen. ISO UT mode supports plug-and-play operation for direct control of major sprayer controllers with industry standard ISO11783. The X30 and X25 consoles also support ISO task control (TC) based rate control (RC) and section control (SC) for compatible ISO ECUs.



X30

XLinks simplifies interface for ASC and VRC

XLinks allows the interface of an existing controller with the Topcon X30 and X25 consoles to provide auto section control (ASC) and variable rate control (VRC). XLinks provides virtually any controller with basic functionality to maintain usability versus re-wiring the implement and installing a new control module.



X30

Crop Monitoring Technology

CropSpec™ crop canopy sensors offer just-in-time crop health management

Topcon CropSpec crop canopy sensors work with the X30 and X25 consoles to monitor in-field variability, treat on the go, or save data for future analysis and creation of prescription maps.

Based on the Topcon core competency of optics, CropSpec uses pulsing laser diodes to scan crop health and nutrition needs. The CropSpec units mount on the cabin roof out of harm's way, with less potential for damage while the high roof top mounting provides the largest sensor footprint in the industry. With angled mounting, reflectance readings are more consistent in thin stands and less susceptible to wind movements.

CropSpec sensors measure plant reflectance to determine chlorophyll content, which correlates to nitrogen concentration in the leaf. This non-destructive, non-contact measurement method provides accurate, stable readings with repeatable values both day and night as well as week to week.



The right product, at the right rate, at the right time, in the right place

- CropSpec crop canopy sensors reduce fertilizer costs by applying based only on crop need
- Create prescription maps, or prescribe and apply in a single pass
- 24/7 operation offers consistent readings day and night
- Largest sensor footprint in the industry reads a larger percentage of the area to be applied
- Views crops at a uniform angle to the crop rather than directly above to minimize the effects of shadowing, crop movement, etc.
- Provides on-the-go averaging with user-determined target rates
- Operates without the need of Nitrogen rich crop area



Connecting Field to Farm Office

SGIS software imports and manages CropSpec data to create prescription maps. SGISfarm and SGISpro are designed to maximize efficiency in the office as well as in the field. Pre-packaged templates in SGISfarm or user-definable templates in SGISpro make it easy to import CropSpec data, soil test, yield and as-applied data for decision making that maximizes the profitability of a farming operation.

MAGNET Mobile AG Network connects field to office for increased productivity. MAGNET is a web browser-based environment that simplifies managing field and office data in the cloud. MAGNET allows easy file transfer between SGIS and Topcon consoles using Horizon software. File transfer brings easy access to all of the valuable data generated by Topcon CropSpec crop canopy sensors.

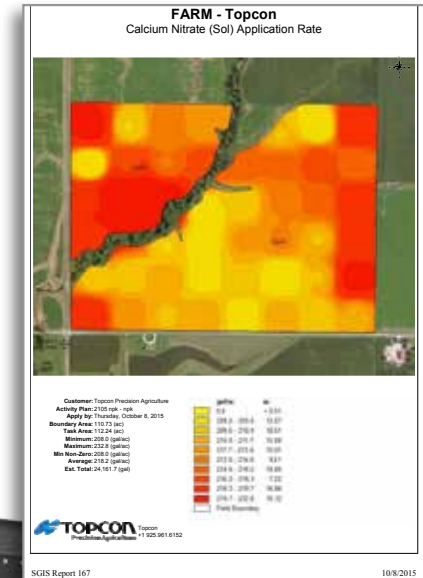



Boom Height Control

NORAC Systems pioneered the use of ultrasonic sensing in the development of control equipment for the agricultural industry. It is currently the world leader in boom height control systems that automatically keep the sprayer boom at the correct distance from the top of the crop or the ground.

These boom height control systems utilize ultrasonic sensors mounted on the left, right and center sections of a sprayer boom to automatically maintain a preset height of the entire boom above the ground or crop.

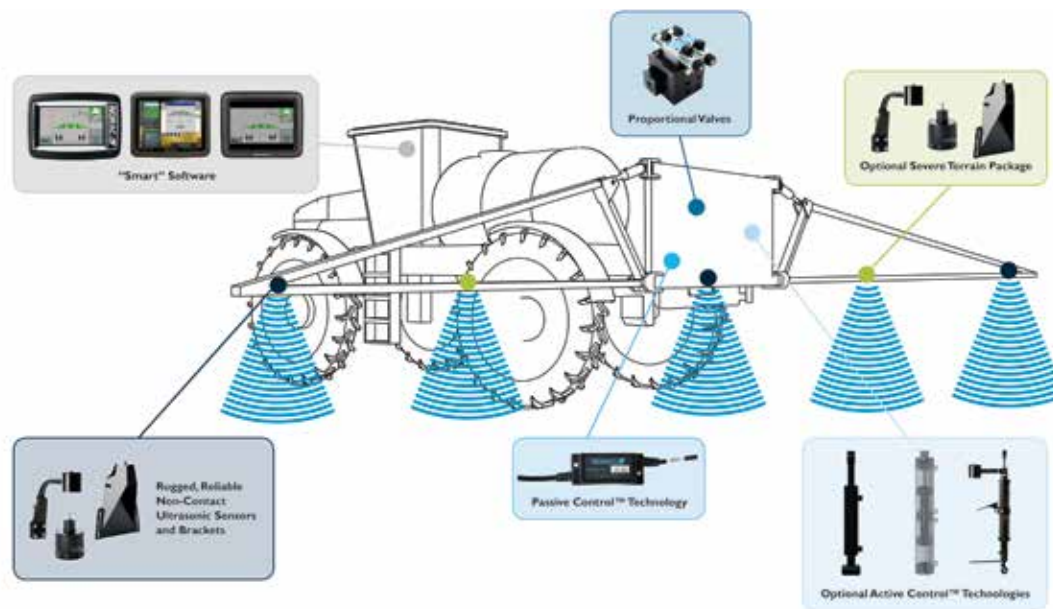



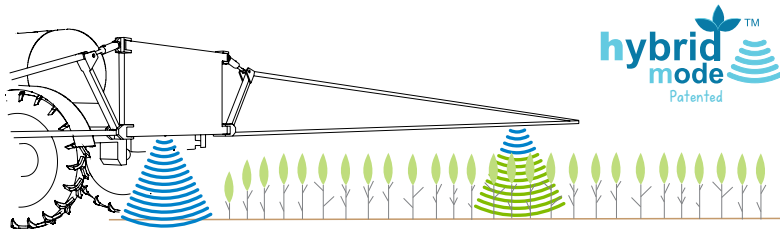

NORAC UC5™ Boom Height Control System

NORAC's UC5™ Boom Height Control System is ISOBUS11783 certified and can be operated through any Virtual Terminal including the Topcon X30 and X25 displays. The UC5™ system is the most advanced boom height control system offered on the market today.

Hybrid Mode™ offers advanced crop sensing for in-crop spraying. It eliminates the need for the operator to take manual control of the boom while spraying in row crops or adverse situations such as lodged, thin and uneven crop. Only NORAC provides the boom stability and boom height accuracy you can trust in all field conditions.

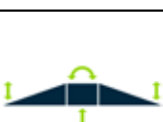

Functions Controlled					
Level of Control	Control Functions	Description	Main Control	Wings	
				On/Off Valves	Proportional Control
Slant Control™		NORAC's Slant Control™ system automatically controls the main lift and slant of the sprayer's center section. It compensates for side hills and slopes to maintain a pre-set height above the ground or crop.	Standard	N/A	
Standard Control™		NORAC's Standard Control™ system is intended for booms up to 90' and for use in less challenging terrain. The system automatically controls wing lift using the sprayer's existing on/off valves to maintain a pre-set height above the ground or crop.	Optional	X	
Passive Roll™		NORAC's Passive Roll™ system automatically measures and compensates for roll in the center section while controlling wing lift independently. The system prevents one boom's action from affecting the other while maintaining a pre-set height above the ground or crop.	Standard		X
Active Roll™		NORAC's Active Roll™ system automatically measures and controls the roll of the center section while controlling the wing lift and main lift independently. By rotating and controlling the center section, wing lift speeds are increased and spray height is maintained even in the most severe conditions.	Standard		X
Active Wing Roll™		NORAC's Active Wing Roll™ system automatically controls the wing lift and main lift independently while hydraulically linking the left and right wings to simulate roll. Isolating the chassis movement from the boom allows for more precise control in challenging terrain.	Standard		X

Spreading Solutions



Variable rate control of granular fertilizers or dry manure

Variable rate capability accurately controls liquid or granular nitrogen and fertilizer application and can be performed from imported prescription maps or generated real-time as-applied maps.

Topcon consoles are compatible with common spreader hydraulic systems and support belt or actuator driven spreaders as well. Control or monitor up to two spinners or control multiple belts or split belt configurations with ASC, or auto section control using the ASC-10 controller.



Topcon X30 and X25 consoles with Horizon software offer high accuracy variable rate control of liquid or granular fertilizers.

CropSpec crop canopy sensors are the ideal dry fertilizer control system. Working on the go, CropSpec helps place fertilizer at the right rate, at the right time, in the right place.



Spreading Solutions



RDS Speed and Area Meter (SAM400)

Measure and monitor your field work progress whilst spreading or any other field activity, monitors area, distance, time, and rate.

- Monitor forwards and shaft RPM
- Measures parts/total area, part total distance, operating, hour and work rate
- Programmable alarms



RDS ISOCAN Athene

Fast, accurate response in a user-friendly regulation and monitoring system for manure spreaders. The RDS ISOCAN Athene spreader control system ensures the maximum nutrient value is extracted from all types of manure and animal waste.

Featuring variable rate technology, the correct application rate is applied irrespective of changes in forward speed and product density.





Spreader Scale Solutions



Nutrient Tracker™

Digi-Star Nutrient Tracker gives accurate, real-time application information. Record keeping of nutrient land application is made simple with Nutrient Tracker. It combines GPS and weight information for accurate verification of manure applications.

- Protection with application verification of your Nutrient Management Plan
- Comply with governmental regulations
- Weigh scales help calculate per acre nutrient application
- Reduce cost by minimizing amount of supplemental fertilizer needed

NT8000i



RDS ISOCAN Athene

Offers fast, accurate response in a user-friendly regulation and monitoring system for manure spreaders.



Interface with both spreader control and load cells

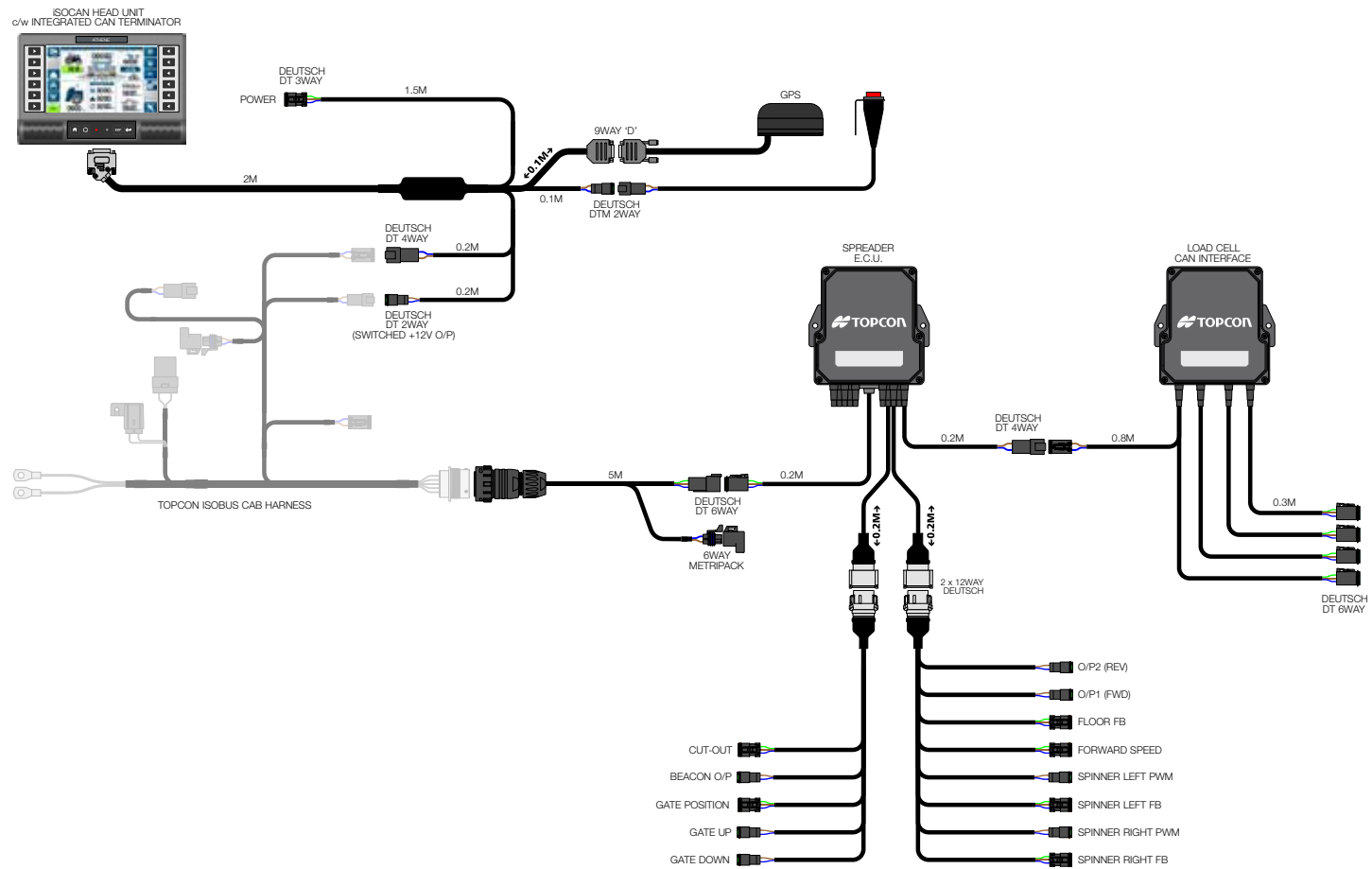

Yield Monitor Solution

YieldTrakk™ offers real-time yield/moisture monitoring and mapping



New to the market, yet reinforced by years of Topcon expertise in optical sensing Topcon YieldTrakk brings an industry- and field-proven optical-based yield monitoring solution to its market leading steering, positioning, and machine control product offering. Obtain a new level of high-accuracy yield/moisture monitoring and mapping that provides growers with optimal yield and crop quality data to help maximize productivity and profitability.



YieldTrakk provides real-time monitoring and mapping of yield, moisture and cut rate, as well as the total weight of crop harvested. Integrated with the Topcon Horizon operating system on the X30 touchscreen console, it displays yield and moisture levels in separate sets of data – providing the operator with a more complete understanding of field and crop conditions to enable better agronomic decisions.

The new Topcon YieldTrakk yield monitor system, developed jointly by Topcon and RDS, is an excellent example of the synergy created by the recent expansion of the Topcon family.

Non-contact optical sensor system

The YieldTrakk system monitors the height of grain on each elevator paddle as it passes by a non-contact optical sensor. Using pre-defined calibration, YieldTrakk converts this to volume of crop and from volume calculates weight of crop harvested.



A second sensor in the bubble up auger measures the crop's moisture level and incorporates that into the real-time readout on the X30 display as well as the data used for mapping.

Terrain compensation in the form of an inertial sensor has been integrated into the YieldTrakk YM-1 to provide more accurate yield data and mapping for better decision making.

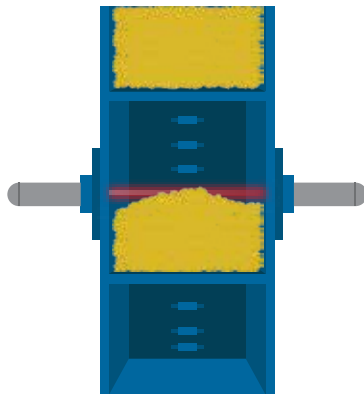

Data in industry standard format for easy export

While many other yield monitor systems utilize proprietary data formats for their data export, YieldTrakk provides data export in industry standard ISOXML and shape file formats.

Topcon SGISfarm and SGISpro software can manage YieldTrakk data for in depth analysis along with many other data management solutions, allowing for import of ISOXML or shape file data layers.

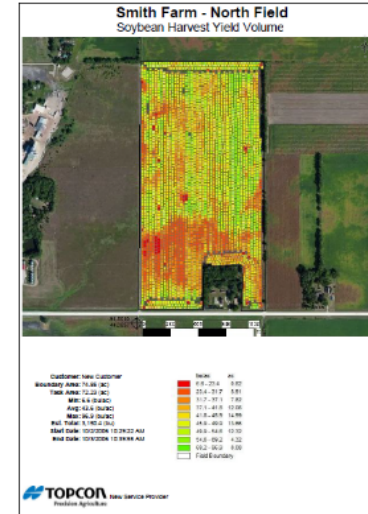



Digi-Star Grain Cart Weighing Solutions



Harvest Tracker™

Calibrate Yield Monitors and Harvest Tracking

This full-featured grain cart interface provides significant field recording and management benefits for producers or custom harvesters. The Harvest Tracker precision automated management system allows easy download of collected data via USB Stick or through the App via WiFi. Proprietary software, easily installed on a PC and accessible online, captures the recorded data and organizes it into reports in excel or PDF-format.

Harvest Tracker is easy-to-use and with AutoLog™2 there are no missed loads. The newly released Harvest Tracker App gives you full control of the system from your phone or tablet.

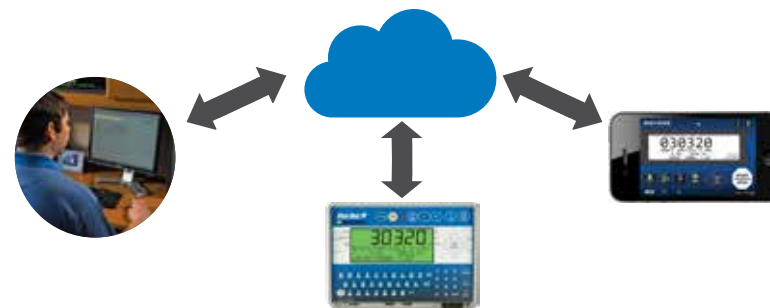

- Measure crop yields
- Compare performance for individual fields,
- Know the exact weight of grain going into or coming out of farm storage
- Keep truck loading from exceeding legal weight limits
- Understand crop damage for insurance documentation
- Save time by weighing in the field
- Make more informed decisions in managing land for highest profitability



Harvest Tracker App

Provides combine operator with remote control of the scale during loading to calibrate Yield Monitor, charge fields, truck ID and more.

Upgrade grain carts equipped with simple scale systems

GT 465

The GT 465 Harvest Tracker system utilizes the tractor's ISOBUS terminal or a Topcon X25 or X30 to decrease cab clutter. The system is easy-to-learn, easy-to-use, features increased remote viewing options and is compatible with the leading virtual terminals in agriculture.



GT 460

Full featured grain cart interface system provides significant field recording and management benefits for producers or custom harvesters.

Door Control Grain Cart Scale

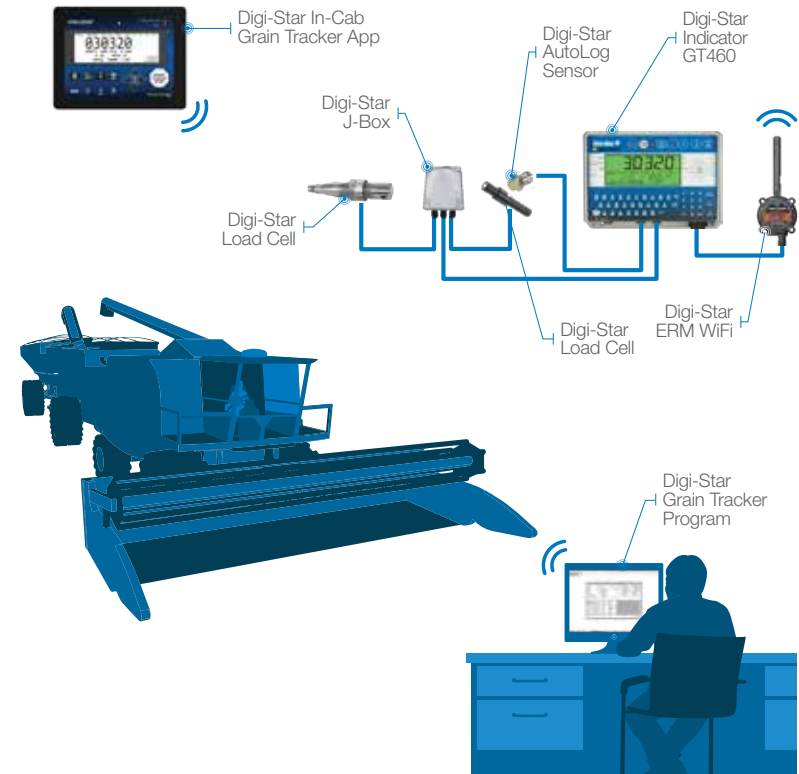



Livestock Weighing Solutions



Low Profile Platform Scale System with SW6600 Load Cells

With a quiet, maximum grip, nonskid rubber mat from Animat, this platform is available with SW3300 or with SW6600 load cells. It has no sharp edges and sits low to the ground, providing maximum safety and security for your livestock.

Stockweigh

The Digi-Star weighing systems are designed for the rugged animal-weighing environment. Advanced signal filtering coupled with Digi-Star's unique Lock-On feature helps provide stable readings despite restless animal movement. The 14-segment backlit display provides excellent visibility in all environments.

- Easy calibration for different load cell configuration
- Compatible with any Digi-Star load cell configuration
- Lock-on weighing
- Bright back-lit display
- Front panel programmability for easy set-up and calibration
- Multi-language "Help" messages in 7 languages



SW4600 EID Recording Indicator

Advanced management indicator allows for both Electronic Identification EID and Visual ID input with customizable display offering easy data collection.

- Temperature compensated indicator option
- Compact, battery operated or recording indicator option

On-Board Weighing Solutions



Advanced retrofit system for use on: wheel, telescopic, tractor, and skidsteer loaders. Can also be fitted to front loaders for tractors and skid steer vehicles

RDS Weighlog α10 on-board weighing system

A powerful system that is simple to install and use. Use it for trailer/hopper loading, large round and square bale handling, and check weighing. Also provides batch blending capability. Maximizes productivity, reduces vehicle movement, fuel usage and machine and tire wear.



- Color touchscreen technology give clear uncluttered information with intuitive operation
- Target Load ensures correct loading of vehicles or products
- Stores weight data – 30 customers, products and 3 mixing recipes for accurate record keeping
- Static and Dynamic Weighing modes for “weighing on the lift” for faster operation
- Multi-channel and grand total summary allows different setups for up to 5 machine attachments (eg. buckets, forks, etc.)
- Load Data Transfer by USB stick or SD card download; a printer option is also available



Precision Feed Management Solutions



Beef Tracker™

Digi-Star precision feed management solutions

Beef Tracker is a Windows® based feed management software program that works in conjunction with the scales on your feed mixer wagon/truck and allows you to accurately and easily collect and manage feedlot nutrition.

Economical and independent program providing tools for:

- Bunk reading
- Feed inventory management
- Lot tracking
- Close out reports
- Easy daily feed adjustments
- Operator accuracy
- Detailed loading and delivery reports
- Quick dashboard with key performance indicators
- Dry Matter Intake (DMI)
- Customizable report generators
- Tracking feed cost

Moisture Tracker™

The Digi-Star Moisture Tracker hand-held, Near-Infra-Red (NIR) scanning device rapidly measures the dry matter and moisture content of animal feeds. Moisture Tracker provides livestock producers with near instantaneous, accurate dry matter and moisture readings, which enable them to quickly react to changes in moisture or dry matter. This ensures that the ration delivered matches the ration calculated to meet animal nutritional needs.

Livestock producers and nutritionists can utilize the information gathered by Moisture Tracker to provide more consistent rations with the goal of reducing cost and waste and improving productivity, herd health, and profitability.



TMR Tracker

TMR Tracker is a full-featured Windows® based feed management system. Digi-Star TMR Tracker offers operators additional management tools including: operator control, pen review, online feed data exchange with nutritionists, ingredient tracking and numerous reports. TMR Tracker is an indispensable management tool for forward thinking operations to minimize cost and increase profitability.

- Works with most herd management programs
- Increased production through consistent feeding
- Employee and mixer management tools
- Moisture Tracker software integration
- Capable of truck scale integration

TST 7600 Indicator

This full featured mixer scale indicator allows producers to make recipe adjustments at the mixer and records the data for use in TMR Tracker.



With the TST 7600 feed managers can change dry matter (DM) and record refusals on the Indicator eliminating additional paperwork in the cab. The resistive type touchscreen functions even when gloves are worn. Clear graphics and intuitive buttons make training new operators easier. The TST 7600 works in conjunction with any of the Digi-Star scale indicators and is compatible with most of Digi-Star's wireless communication systems.

DataLink Wireless data transfer systems for TMR Tracker and Beef Tracker

Digi-Star DataLink wireless system continuously looks for pen-fed data and feeding vehicle readiness to receive the next ration and/or pen feeding information.

- Flexible, multiple feed process options
- Multi-language support
- Manage load-by-load ingredient loading and pen feeding information
- Send all pen feeding data - operator manages pen feeding
- Manage ingredient data to stationary mixer or batch box
- Send pen list to delivery truck
- Links to third party bunk read software

Water Conservation and Landforming

Proven field design and landforming with GNSS accuracy

Topcon offers dual-constellation (GPS + GLONASS) satellite reception for maximum accuracy with single or dual scraper control, plus the ability to grade more than 12,000 acres/4,800 hectares in a single setup. The GNSS system offers 24/7 operation and can work in dusty conditions that would significantly hamper use of laser.

The Topcon GNSS solution allows the operator to survey, create cut/fill maps and start grading without ever leaving the cab. Best-fit calculations reduce yardage up to 10% versus traditional hand-calculated laser surveys.

Topcon X30 offers high-accuracy landforming and autosteering simultaneous on a single console.

World's best landleveling with world's best autosteering: Topcon X30 console, using Horizon software, can now be teamed with the AGI-4 Receiver/Steering Controller to bring the best of both worlds in one solution.



MC-R3 contains GPS receivers, radios and controllers in one rugged unit. Features Ethernet port, power processing capability and additional valve drivers for the widest array of machine compatibility.

MC-A1 is a precision dual-frequency, dual-constellation antenna featuring micro-center technology plus integrated ground plane to reduce multipath errors.

HiPer V/GR-5 mobile base station integrates receiver, radio, antennas and a rechargeable battery to function as a mobile, cable-free base station, fixed base or survey rover.

CR-G5 Dome Antenna –exceptional performance in more demanding multipath-prone environments.



AGForm-3D Software with Variable Slope PWCS

AGForm-3D state-of-the-art survey and design software coupled with HiPer V receiver/base station is used for independent survey of fields and creating flat, single and dual slopes, or multi-slopes without leaving the vehicle cab.

Topcon PWCS or Piecewise Continuous Slope has revolutionized land leveling by significantly reducing the volume of material moved and by keeping design surfaces closer to the original terrain than older multi-planar methods.

AGForm-3D offers complete control with the ability to survey, design and create plots and reports in a single program. And, with no per-acre fees, it's a one-time investment that generates rewards immediately.

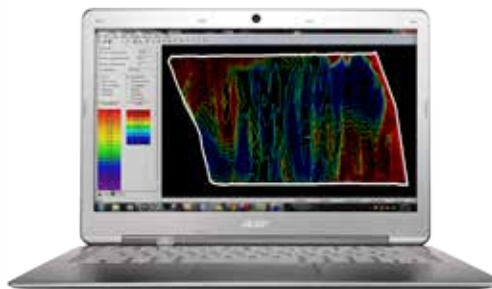

Laser Land Leveling

Topcon laser systems offer time and field proven technology, with single or dual scraper control and flexible options to suit your leveling needs from basic manual indicate to fully automatic machine control.

System 5

Dual Control 9164 – Elevation control for two scrapers, or slope and elevation on a single scraper. Combine with the TM-1 survey masts or use rigid masts for economy.

Single Control 9256 – Combine with the TM-1 mast and LS-B110 laser receiver for automatic control and survey capabilities on a single scraper. Survey function adds, then averages elevations. Perfect for field leveling or maintaining roads or ditch pads.

RL-200 Series Single and Dual Slope Lasers

Topcon RL-200 Series lasers set new standards for simplicity and accuracy. Rugged, lightweight, and compact – an amazing laser for an affordable price.

Choose from two models, RL-200 1S single slope or RL-200 2S dual slope. The RL-200 1S provides single slopes from -5% up to +25% and the RL-200 2S provides dual slopes up to +/- 10% in the X axis, or up to an industry-leading -5 to +25% in the Y axis.

Large, high-contrast, graphical display clearly shows all functions at a glance. Revolutionary encoding system provides the highest grade repeatability (7 arc seconds) of any laser.



9256



LS-B110

Laser Receiver

Visual grade indicators for manual control or automatic mode for cutting-edge hydraulic elevation control. Features 360° reception, bright multi-color grade indicators, adjustable on-grade accuracy, waterproof, dustproof, alkaline or rechargeable battery, and plumb indicator.



TM-1 Electric Mast

The TM-1 mounts on the scraper mainframe where it raises and lowers the laser receiver for quick, accurate surveys.





Mobile Ag Network (MAGNET)

Mobile AG Network File Transfer connects Field to Office for increased productivity

MAGNET is a web browser-based environment that simplifies managing field and office data in the cloud. MAGNET allows easy file transfer between SGIS and Topcon consoles using Horizon software.

MAGNET can be obtained through monthly or annual license subscriptions and can accept any number of users in a single account. Once a MAGNET Mobile Exchange Ag Application is set up, the user can then transfer data files from various vehicles to the cloud where it is accessible from the office or other machines.

MAGNET Mobile Ag Network file transfer brings easy access to all of the valuable data generated by Topcon precision ag solutions.

Download to the X30 Console

- VRC prescription maps in Shapefile format
- VRC prescription maps in ISO XML format

Upload from the X30 Console

- As-applied maps in Shapefile format
- Coverage Shapefiles
- Boundary Shapefiles
- PDF job reports
- “Per point data” files
- ISO XML files

MAGNET Mobile Exchange for Ag

MAGNET Mobile Exchange for ag is a standalone software product that can be used by anyone with an existing Company Account within the Mobile AG Network website. MAGNET Mobile Exchange is available at no-cost as a Mobile Ag Network subscriber (no need to activate with software serial number).

- Connects to Mobile Ag Network
- Exchange any file type
- Chat message new orders
- Update progress
- Receive news feeds about updates





MAGNET™
MOBILE AG NETWORK

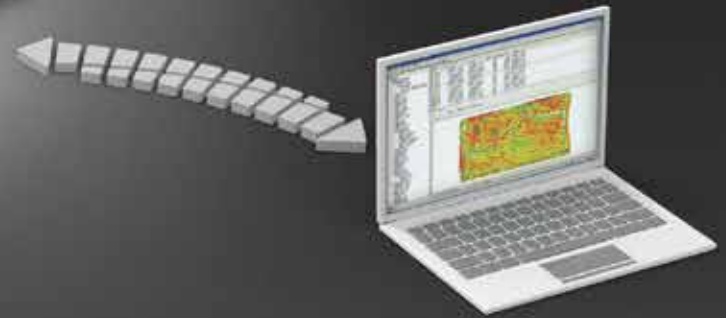
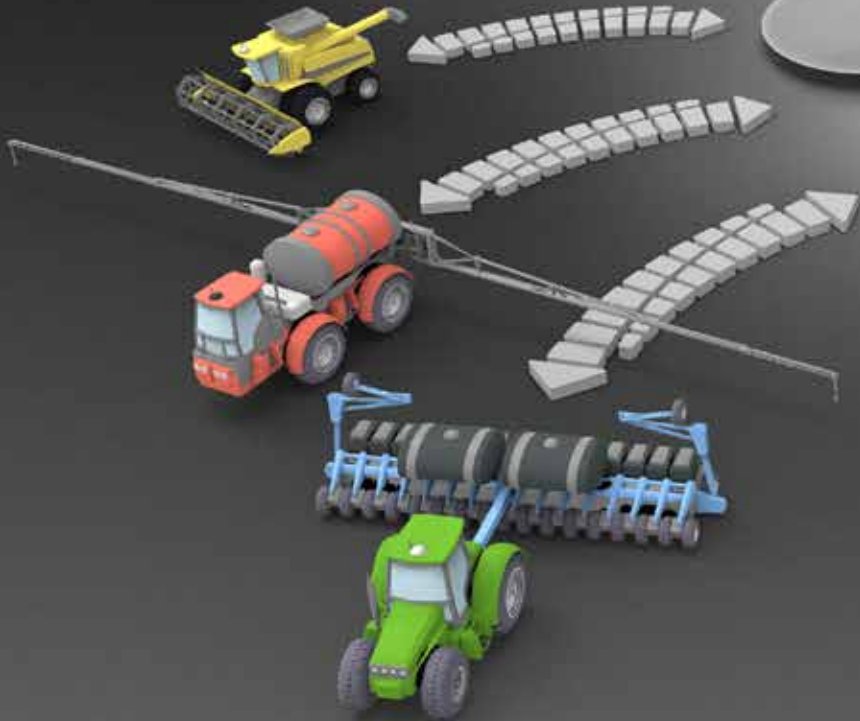

Data Management Solutions

A strong precision heritage

For over 20 years, SGIS agronomy software had been sold almost exclusively in the ag retailer market where it became a key technology component of many successful precision farming service businesses. As the “engine” behind your precision agriculture effort, SGIS delivers insight, puts you in control and impacts profitability. SGIS converts yield, soil sample and other agricultural data into geo-referenced maps that professionals can use to better understand crop performance and make more accurate application plans.

Users can efficiently and effectively offer multi-product and variable-rate plans that are customized to growers’ local conditions and requirements. SGIS software guides agronomic and economic recommendations—and more profitable crop production decisions.

Topcon SGIS data management solutions now include SGISfarm, for farm owners and operators, SGISpro for the professional agronomist, and now SGIEnterprise which provides precision data management in multi-user environments.

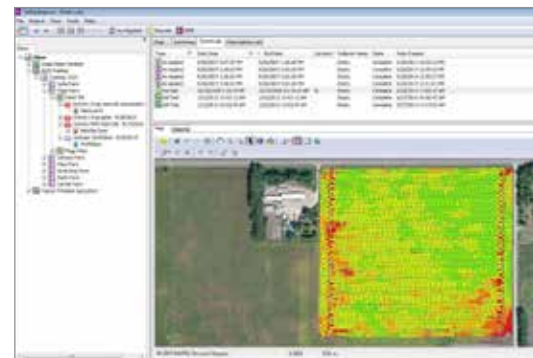
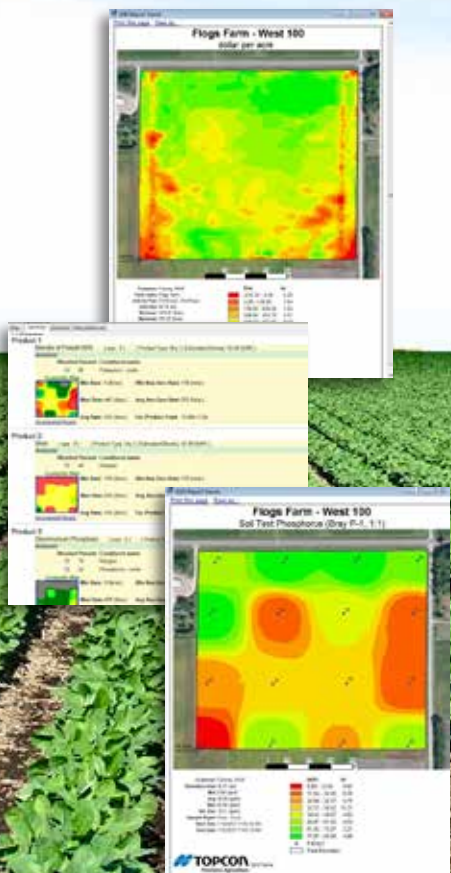

SGISfarm

Simple-to-use data management for farm owners and operators

SGISfarm is built around the industry-leading Esri ArcGIS Engine 10.1 – the same engine used by local FSA and government offices. SGISfarm features an easy-to-use process to streamline the creation of flat and variable rate maps without sacrificing quality or accuracy. This process is focused on proven recommendation methods that are pre-packaged in readily available templates to eliminate the complex process of equation creation. SGISfarm works well alone, or as companion software to SGISpro.

SGISfarm imports and manages all types of data that are critical to a successful farming operation. Data types include: soil test, yield and as-applied data as well as crop sensor, soils and topography information. SGISfarm supports an extensive list of third party application, yield and seeder controllers; and makes it easy to either create application maps for, or import data from those systems.

SGISpro

Data management and analysis for the professional agronomist

With over 20 years of proven, in-field experience coupled with the industry-leading Esri ArcGIS Engine 10.1, SGISpro is tailor-made for the co-op, agronomist or technology-minded farmer. SGISpro builds on the functionality of SGISfarm by adding in many powerful analysis tools that can be used to highlight the relationships between yields, soil testing information and application data. SGISpro users can efficiently and effectively offer multi-product and VRT plans customized to suit a grower's exact requirements and demands.

SGISpro features an industry-exclusive process for tailoring variable rate applications to include local requirements as well as customers' specific requests. This feature sets SGIS apart as the most powerful agronomic tool available to allow users to utilize their knowledge of local conditions and preferred practices to guide the development and implementation of accurate variable rate applications.

SGISenterprise

Streamlining collaboration between multiple SGIS users

SGISenterprise allows multiple users to access the same database to make collaboration and sharing of data much faster and more intuitive across multiple workstations or locations.

What sets Topcon apart is that we provide users the opportunity to maintain full control and access to their data – it is not uploaded to a server in some remote location but stored on a local server at the customer's location.

SGISenterprise opens up a new range of possibilities for interconnectedness between the farmer and the agronomist. SGISpro and SGISfarm users can collaborate and access the same database. This means that a Pro user can manage multiple Farm users and access all of their data. At the same time, producers can be limited to only viewing the data that is pertinent to their operation.



www.topconpositioning.com



www.digi-star.com



www.rdstec.com



www.norac.ca



www.wachendorff-elektronik.de

